

TGC

蒸氣洗衣機
STEAM WASHER

洗衣新選擇

蒸氣抗菌 · 護衣 · 防皺



TWM800

A Fresh Choice for Laundry
Steam Hygiene · Fabric Care · Wrinkle-Free

24x7
客戶服務熱線
CS Hotline



蒸氣護理
Spa Care



高溫潔筒功能
Drum Clean



變頻摩打
Inverter Motor



13種洗衣程序
Washing Mode



中途添增衣物
Reload



超快洗模式
Quick 15

TGC 前置式洗衣機

FRONT LOADING WASHER TWM800



- ◆ 「蒸氣護理」功能產生溫暖蒸氣優化洗滌效果。
"Spa Care" function generates warm steam to enhance washing performance.
- ◆ 「滾筒清洗」功能以高溫清潔滾筒和管道，確保衛生。
"Drum Clean" function which use high-temperature to clean the drum and tube for enhanced hygiene.
- ◆ 變頻摩打減少機件震動，提供安靜、可靠的性能。
Inverter Motor minimizes mechanical vibrations, delivering quiet and reliable performance.
- ◆ 「15分鐘快洗」提供高效的15分鐘快洗模式。
"Quick 15" offers an efficient 15-minute wash mode.
- ◆ 「添放衣物」功能容許洗衣過程中添加遺忘的衣物。
"Reload" function allows the washing program to be paused, enabling the reload of more clothes.
- ◆ 「污垢程度」功能洗衣時間會因應選擇的污垢程度增加或減少。
"Soil Level" function can be selected to increase or decrease the washing time.

產品規格 PRODUCT SPECIFICATION

顏色 Colour	白色 White
整體尺寸：高 x 闊 x 深 (毫米/吋) Dimensions : H x W x D (mm/inch)	850 x 595 x 540 / 33.5 x 23.4 x 21.3
洗衣量 (公斤) Washing Capacity (kg)	8
最高脫水轉速 (每分鐘轉動) Maximum Spin Speed (r.p.m)	1400
洗衣程序選擇 Number of Washing Programs	13 (棉質；合成纖維；混合布料；床單；嬰兒柔洗；20度水溫；15分鐘快洗；強力洗；40-60度節能洗；羊毛；過水及脫水；淨脫水；滾筒清洗 Cotton；Synthetic；Mix；Bed Linen；Baby Care；20°C；Quick 15'；Intensive；Eco 40-60；Wool；Rinse & Spin；Spin Only；Drum Clean)
延時洗衣 (小時) Delay Time (hours)	1-24
輸入功率 (瓦) Rated power (W)	1950
水溫選擇 (度) Temperature Selection (°C)	冷水 Cold、20°C、30°C、40°C、60°C 及 90°C
摩打 Motor	變頻摩打 Inverter motor
電源供應 (伏特 / 赫) Electric Supply (V / Hz)	220-240 / 50

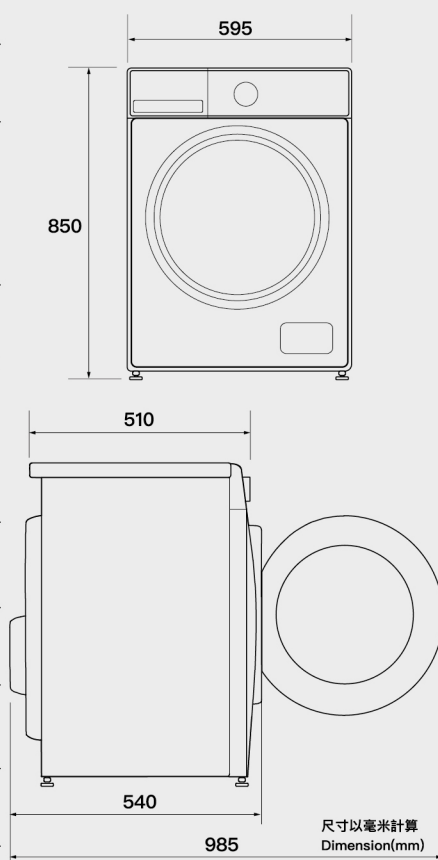

免費3年保養[^]
Free 3 years warranty[^]

免費送貨服務[^]
Free delivery service[^]

免費標準安裝[^]
Free standard installation[^]

查詢或訂購

For enquiries or to place order:

產品銷售熱線
Sales Hotline: **2232 1000**

各名氣家煤氣客戶中心
Any Towngas Lifestyle Customer Centre

[^]免費維修保養及送貨安裝服務只適用於車輛能直接到達的住宅用戶，而馬灣及愉景灣須收取附加費。所有離島及行使禁區的地區則不獲提供有關服務。本公司不會為產品因不適當安裝、操作、濫用或錯誤使用等情況而引致的損壞提供三年免費更換零件保養服務。此保養服務並不包括外觀及消耗性零件（如外殼、製鈕、過濾網袋、去水喉、洗衣機門玻璃、線屑過濾器、洗衣劑盛載器及所有配件）的更換。價格及規格如有更改，恕不另行通知。所有圖片只供參考。

[^] Free warranty, delivery and installation servicing are only available for residential customers living in the areas which can be reached by vehicles. Surcharge will be applied to the orders of Ma Wan and Discovery Bay. No service will be provided for all outlying islands and restricted areas. Our company will not provide the 3-year free spare parts replacement warranty service to any product damages resulting from improper installation, mishandling, abuse of use and misuse of our products. This warranty service does not cover exterior components and consumable parts (e.g. replacement of case, knobs, filter mesh bag, drain hose, washing machine door glass, thread dust filter, detergent container and all accessories). All prices and specifications are subject to change without notice. All photos are for reference only.

©版權所有。未獲本公司授權，不得翻印、複製或使用本單張作任何用途。

©All rights reserved. Copying, reproducing or using the contents of this leaflet are not allowed without prior permission from our company.

Towngas Lifestyle

www.towngasappliance.com

Towngas Lifestyle

Towngas



RM/EAW1/0626