

SIMPA

嵌入式平面爐
Built-in Hob

使用及安裝說明書
User and Installation Instructions

型號 Model
HZB53M1

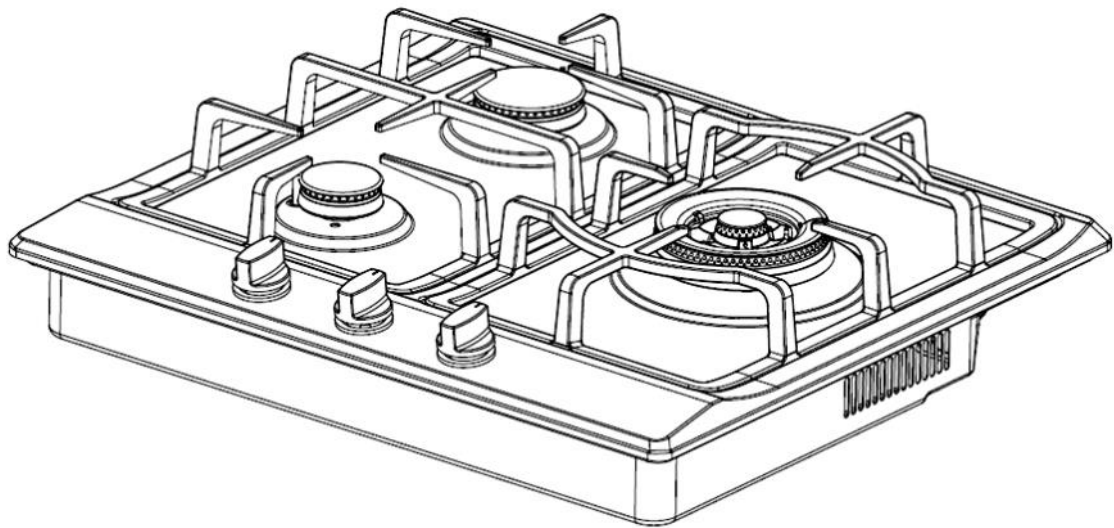

香港煤氣適用
For Hong Kong Town Gas

目錄

重要安全指示	第	1	頁
安裝指示	第	3	頁
操作指示	第	5	頁
清潔及保養.....	第	7	頁
故障處理.....	第	8	頁
規格	第	9	頁

注意!

根據香港氣體安全條例，任何氣體裝置工程，包括爐具和接駁喉管的安裝，必須由註冊氣體裝置技工執行，而該技工已於相關的氣體工程類別註冊及受聘於註冊氣體工程承辦商。

重要安全指示

以下指示對爐具的安全操作十分重要，請詳細閱讀，如有查詢或需要維修服務，請致電 24 小時客戶服務熱線 2880 6988。

安裝

1. 使用認可印有機電工程署批准標記（例如：機電工程署批准 EMSD APPROVAL GTXXXX）的氣體接駁喉管連接爐具，或使用機電工程署接納的其他恰當方法。
2. 檢查供氣壓力是否在 1.5 千帕，此爐具不需安裝外置穩壓器。
3. 當在櫥櫃面安裝嵌入式氣體煮食爐時，檢查面板進風口(如適用)沒有阻塞，以確保煮食爐在使用時操作正常。
4. 爐具必須安裝在空氣流通之房間內。
5. 不要將易燃物品、噴霧及壓縮容器置於爐具周圍及下方的廚櫃內。
6. 爐具與周圍可燃燒物料應保持 150 毫米以上的距離。

使用

1. 當懷疑洩漏氣體時，將窗戶打開，以及關閉煤氣錶閥。切勿操作任何電器或電掣開關。切勿在現場使用任何電話。在現場以外的地方，致電煤氣公司緊急事故熱線，電話：2880 6999。
2. 請參照說明書內指引正確使用爐具。
3. 爐具只供家用，切勿用於工商業用途。
4. 除了煮食外，切勿使用爐具作其他用途，例如烘乾衣物。
5. 使用爐具前，請開啟窗戶和排氣系統。
6. 不可讓兒童使用爐具。
7. 切勿讓爐具在無人看管下運作。
8. 切勿在爐頭加上錫紙碟，這會引致燃燒問題。
9. 只可使用原廠認可的配件，避免導致潛在的健康風險或財物損失，如一氧化碳中毒或火警。
10. 請確保爐頭蓋及爐頭身沒有變形，如有異常，請聯絡客戶服務安排更換。
11. 使用前，請確保爐頭蓋、爐頭身和爐架擺放正確，沒有傾斜。
12. 請確保爐頭火孔沒有被水或污漬堵塞。
13. 在一個爐架上，切勿放置超過10公斤的重量。
14. 爐架很重的，切勿掉下。
15. 不應按下點火旋鈕超過 10 秒。如爐頭於10 秒後仍未燃點，等待最少1分鐘後，才再試燃點。
16. 請確保使用時火焰平均。
17. 注意爐面、爐頭及爐架的高溫。
18. 切勿使用直徑過大的平底煮食器皿，避免溫度過高而造成燙傷及影響爐具的使用壽命。使用細小器皿時，請將火力調低，避免火焰超出器皿底部。

	爐頭	最大平底煮食器皿直徑 (毫米)
	左 - 上爐頭	220
	左 - 下爐頭	200
	右爐頭	280

19. 請確保器皿穩定地放在爐架上，如器皿容易滑動，必須緊握它。
20. 面板是固定的，切勿移動。

重要安全指示

21. 燒開水或煮湯時，注入的水量連湯料不可超過器皿容量三分之二，溢出液體會影響燃燒和損壞爐具。
22. 使用小火時，不應急速打開爐具下方的廚櫃門，以免氣流弄熄爐火。
23. 烹調時，請盡量蓋上鍋具。而鍋具的手柄亦應轉向適當位置，避免受熱或碰撞。
24. 請勿在爐具附近使用噴霧產品。
25. 使用後，應將所有旋鈕設於關閉位置。
26. 經常清潔爐頭以保持火孔暢通，如滾瀉食物及汁液，應在爐具冷卻後儘快清潔爐頭。

保養

1. 定期檢查氣體喉管狀況，確保沒有紐結或裂縫，若發現損壞，請聯絡客戶服務更換喉管。
2. 讓爐具完全冷卻後，才可進行清潔。
3. 進行清潔時，應穿上保護手套避免割傷。避免接觸爐具的內部位置。
4. 清洗爐頭蓋及爐頭身後，用乾布將爐頭蓋完全抹乾，爐頭火孔不可留水份，以免影響燃燒。
5. 使用前和使用後，注意爐頭的狀況和清潔。以下不正常狀況會產生燃燒不良，進而引致爐具損壞。請確保採取相應措施，糾正有關問題。
6. 待爐具完全冷卻後，才可進行任何保養及清潔。請徹底清潔爐架或爐頭的水漬、湯汁及食物殘渣。風乾的殘留物可能會變成頑固污漬及導致爐架或爐頭變色。

不正常情況	處理措施
爐頭蓋和爐頭身變形	聯絡客戶服務更換零件。
爐頭蓋和爐頭身傾斜	將爐頭蓋和爐頭身重新放好，不可傾斜。
爐頭火孔被水堵塞	用布將爐頭蓋及爐頭身抹乾後，重新放好。
爐頭火孔被污積或溢出物堵塞	用溫和清潔劑和刷子清潔爐頭蓋及爐頭身，用布抹乾後，重新放好。

安裝位置

爐具須安裝在空氣流通之房間內，但切勿置於強風直接吹入的位置。附近不可放置易燃物料（如紙張、塑膠、油類）、可燃物料、噴霧及壓縮容器。爐具與周圍可燃物料應保持 150 毫米以上的距離。爐具上方須保留最少 650 毫米空間。安裝於爐具上方的抽油煙機，必須與爐架面保留最少 650 毫米的距離。如抽油煙機要求不同的安裝距離，則採用較大間距。爐具於煮食時的煙氣應經由抽油煙機排走。

此爐具適合安裝的開孔尺寸。

- **開孔尺寸：寬 555 x 深 475 毫米**

依照圖 1 在枱面預留開孔，枱面深度不少於 600 毫米。

若在嵌入式氣體爐具下安裝其他器具（如洗碗碟機、洗衣機）。請保留最少 10 毫米的距離。若下方器具的安裝指引要求不同的間距，應採用較大者。若在嵌入式氣體爐具下方設有會產生氣流的爐具或設備（例如：焗爐、乾衣機），必須加裝隔層板並以矽膠密封所有縫隙，避免氣流影響爐具運作。

安裝爐具

放置爐具於枱面的開孔後，用螺絲將底盤固定。將面板正確安裝於櫃面上，確保面板底部邊緣的膠條緊貼於櫃面上。面板裝妥後，再裝上旋鈕在正確位置。

氣體接駁

根據現行指定的標準，將氣體爐具連接供氣設施上，接駁前確保爐具符合所供應之氣體類型。此外，檢查供氣壓力是否在 1.5 千帕，不需安裝外置穩壓器。



注意

- 爐具的氣體接頭為 1/2 吋英制陽螺紋，使用已批准的氣體喉管接駁爐具。氣體軟喉長度不超過 2000 毫米。確保喉管沒有接觸任何活動部件或被扭曲和擠壓。
- 安裝完成後，檢查接駁後的氣密性。切勿使用明火作檢查。

安裝電池

使用前，必須正確裝上電池。若電池擺放錯誤，爐具便不能操作。

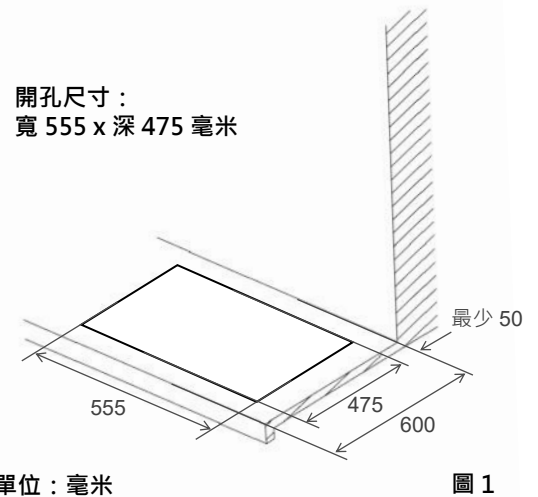



注意

不銹鋼面板必須穩固安裝在爐具底盤上！

- 將不銹鋼面板孔對準爐頭座、點火電極及熄火安全裝置，然後固定。
- 使用螺絲上緊不銹鋼面板。

爐頭放置

使用前，確定以下配件已置於正確位置：

- 右邊爐頭由外環爐頭蓋、芯火爐頭蓋及爐頭身組成。
- 左邊爐頭由爐頭蓋及爐頭身組成。
- 將爐頭蓋及身放置在爐頭座上，放置時請勿傾斜。
- 右邊爐頭身的定位針應對準右邊外環爐頭蓋的定位槽。
- 左邊爐頭身的定位針應對準左邊爐頭座的定位槽。

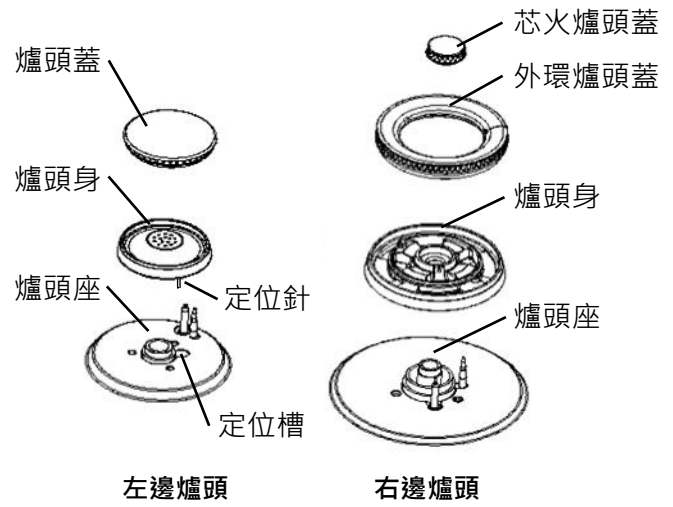

不要在爐頭錯誤放置的情況下使用爐具。

- 若爐頭未放置正確，會導致無法點火。
- 火焰不均和回火會導致不完全燃燒、一氧化碳中毒或爐頭變形。
- 火焰進入爐具內，會導致損毀。

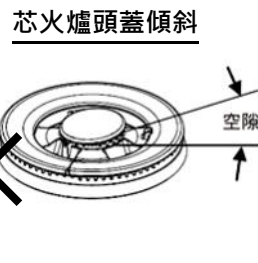
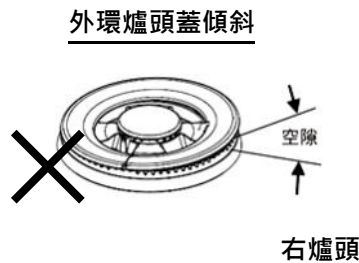
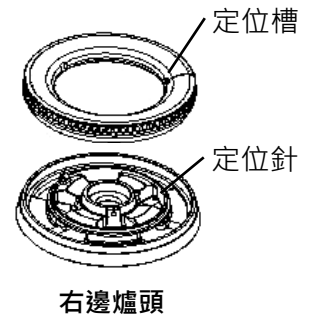

爐架放置

使用前，確定以下配件已置於正確位置。

- 將爐架對準面板平放。



不要在爐架錯誤放置的情況下使用爐具。錯誤放置爐架有機會導致鍋子不穩，並引致危險。

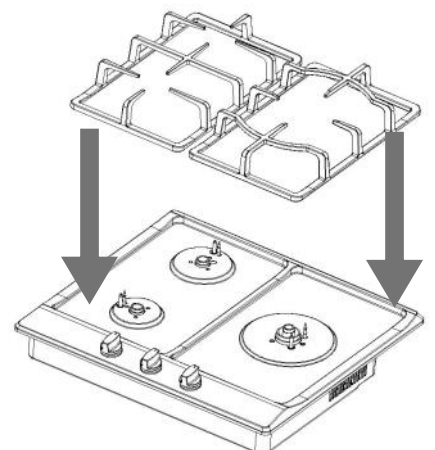

爐具介紹

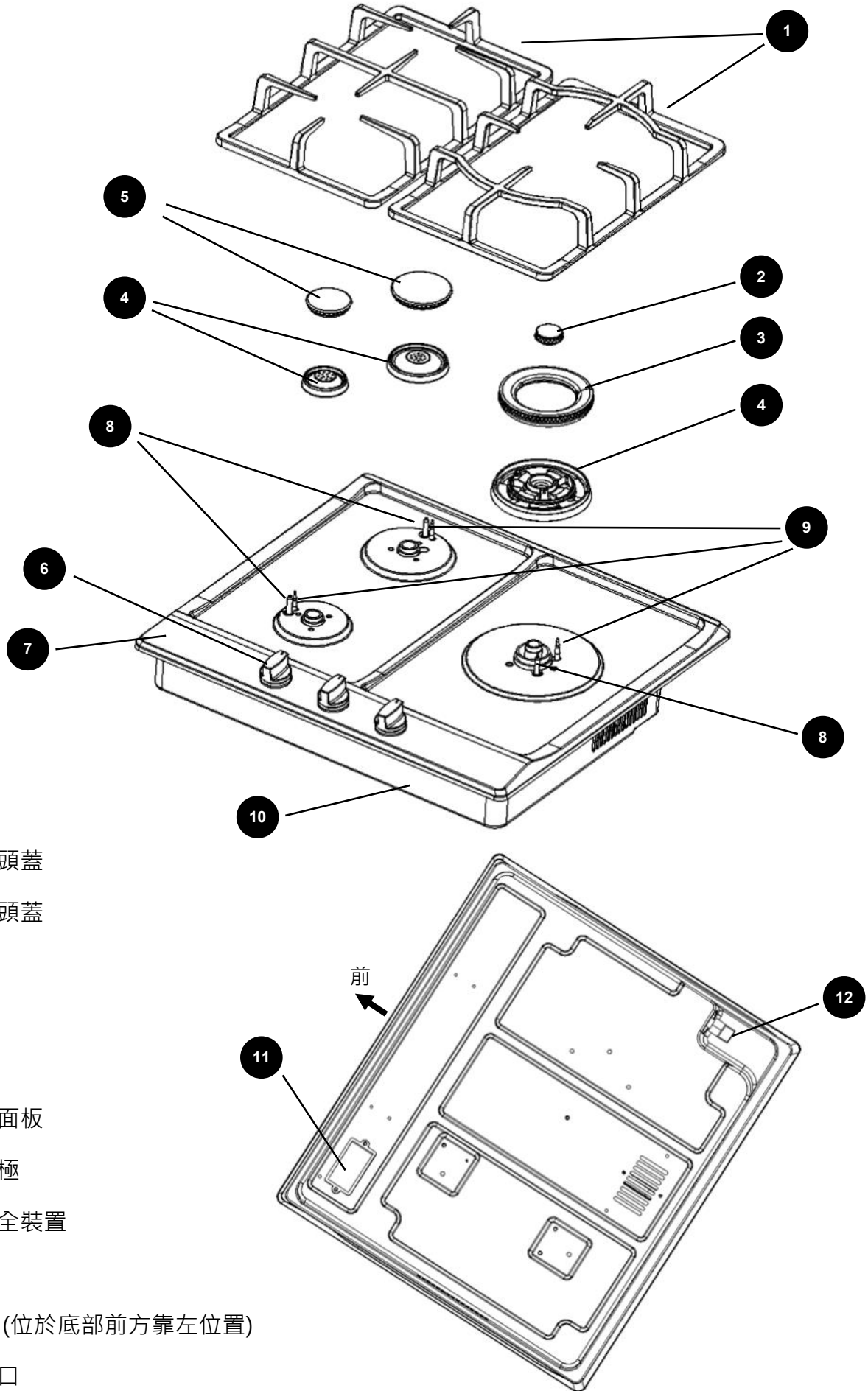

- 1 爐架
- 2 芯火爐頭蓋
- 3 外環爐頭蓋
- 4 爐頭身
- 5 爐頭蓋
- 6 旋鈕
- 7 不銹鋼面板
- 8 點火電極
- 9 熄火安全裝置
- 10 底盤
- 11 電池盒 (位於底部前方靠左位置)
- 12 燃氣接口

旋鈕及標示

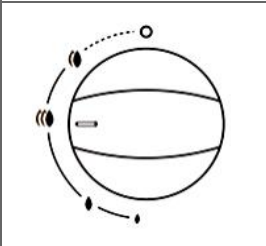
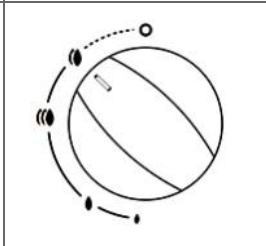
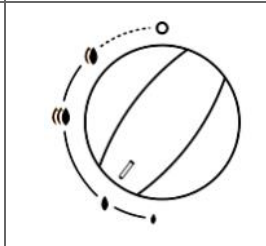
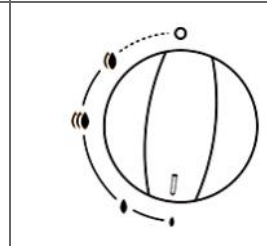
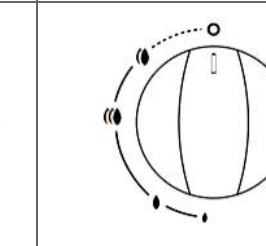
點燃位置 / 最大火力位置	中火位置	中火位置	最小位置	關閉位置
				



注意

- 於爐具運作約 30 分鐘後，爐具不銹鋼面及旋鈕部分有機會因爐火熱力而變熱。如需使用旋鈕部份，可以濕布降溫後使用。

點燃爐頭

完全按下旋鈕同時逆時針方向轉動旋鈕至點燃位置，點火電極會發出火花點燃爐頭。放開旋鈕後，確定火焰維持。



注意

- 如爐具長時間未有使用，於首次點燃時，有機會因喉管內含有空氣而未能令爐頭點燃成功。
- 如爐頭未能燃點，將旋鈕轉至關閉位置。等待最少 1 分鐘後，重複上述點燃步驟至成功點燃爐頭。請勿維持按下旋鈕超過 10 秒。

火力調節

爐頭點燃後，可按烹調所需轉動旋鈕調節火力。請緩慢調節火力。最小火力位置在逆時針轉動方向的盡頭。



注意

- 使用小火時，不應急速打開爐具下方的廚櫃門，以免氣流弄熄爐火。
- 在調較最大火力至接近中火時，若發現外環火焰不穩定(微弱或熄滅)，請立即調大火力，直至外環火焰穩定，才繼續使用；或調小火力，使用芯火(如適用)。
- 在調較火力時，有機會因火力的轉變令爐頭內的氣體瞬間燃燒而出現「撲」聲，此屬正常現象。

關閉爐頭

將旋鈕轉動至關閉位置。



注意

- 關閉爐頭時，有機會因殘留在爐頭內的氣體瞬間燃燒而出現「撲」聲，此屬正常現象。



注意

- 待爐具完全冷卻後，才可進行任何保養及清潔。
- 清潔時，應配帶手套保護雙手。

為妥善保養爐具，遵照以下指示定期清潔爐具：

一般

- 請勿使用蒸氣清潔爐具。
- 使用適當的非研磨及非腐蝕性的清潔劑清潔金屬及搪瓷部份，避免使用含氯清潔劑（如漂白劑）。
- 避免酸性或鹼性物質（如醋、鹽水、檸檬汁等）殘留在爐具。
- 煮食時如有液體溢出，應待爐具冷卻後儘快清理。
- 定期檢查熄火安全裝置及點火電極，如有污物黏附，可使用軟刷將污物去除。
- 不應接觸爐具內部零件。
- 經常檢查氣體喉管情況，如發現有損壞，請致電客戶服務更換。

清潔爐具

- 定期使用暖水及清潔劑清洗爐頭蓋及爐頭身，將污漬去除，並保持爐頭火孔暢通。
- 清潔後須完全抹乾爐頭蓋及爐頭身，並檢查爐頭火孔沒有被堵塞。
- 將爐頭蓋及爐頭身放回正確位置，不可傾斜或反轉。
- 煮食時滾瀉的食物或液體，必須以乾布清潔。



注意

- 於重新點火前，請將旋鈕轉回關閉位置。

如爐具出現異常或故障，應先關火。請先確保爐具完全冷卻後，才進行任何故障處理。如採取以下處理方法後仍然無效，請致電 24小時客戶服務熱線 2880 6988 安排維修。

故障	原因	處理方法
1. 沒有點燃火花	電池已耗盡。	更換電池。
	電池擺放錯誤。	正確裝上電池。
	點火電極上有污垢或沾濕。	清理及抹乾點火電極。
2. 沒有爐火	未開啟燃氣錶閥及 / 或爐具供氣閥。	完全開啟燃氣錶閥及 / 或爐具供氣閥。
	喉管內含有空氣。	重複點火至喉管內空氣完全排出。
	錫紙碟阻塞爐頭。	除去錫紙碟。
	點火電極上有污垢或沾濕。	清理及抹乾點火電極。
3. 不能保持爐火	熄火安全裝置上有污垢。	清理熄火安全裝置。
	未完全按下旋鈕或旋鈕沒有轉至點燃位置。	按下旋鈕及轉至點火位置。
4. 使用中熄火	熄火安全裝置上有污垢。	清理熄火安全裝置。
	爐火過弱被風吹熄，熄火安全裝置啟動。	旋鈕轉至關閉位置。等待1分鐘，重新點火。
	使用小火時，急速打開爐具下方的廚櫃門。	旋鈕轉至關閉位置。等待1分鐘，重新點火。
5. 黃火	爐頭蓋及爐頭身有污垢。	使用暖水及清潔劑清洗爐頭蓋及爐頭身。抹乾後放好，重新點火。
6. 火焰不穩定	爐頭蓋及爐頭身變形。	聯繫客戶服務更換零件。
	爐頭蓋及爐頭身擺放不正確。	旋鈕轉至關閉位置。待爐具冷卻後，重新放好爐頭蓋及爐頭身，並重新點火。
7. 鬆開控制旋鈕後，點燃火花仍然持續	為方便點燃爐頭，點燃火花會維持最多 10 秒。	屬正常，不需處理。
8. 使用中現異常聲響	爐頭蓋和爐頭身擺放不正確。	旋鈕轉至關閉位置。待爐具冷卻後，重新放好爐頭蓋及爐頭身，並重新點火。
9. 調較火力或關火時出現「撲」聲	殘留在爐頭內氣體瞬間燃燒。	屬正常，不需處理。

規格

型號		HZB53M1	
基本規格	爐具類別	氣體煮食爐	
	安裝方式	嵌入式	
	氣體種類	香港煤氣	
	供氣壓力 (千帕)	1.5	
	穩壓器出口壓力 (千帕)	/	
	氣體接駁	1/2 吋英制陽螺紋	
	點火裝置	快易電子點火	
	爐頭數目	3	
	額定熱負荷 (千瓦)	左 — 上爐頭	2.5
		左 — 下爐頭	1.3
		右爐頭	5
		總	8.8
	面板物料	不銹鋼	
	面板厚度 (毫米)	/	
	爐具尺寸 - 高 x 闊 x 深 (毫米)	底盤至廚檯面	55 x 580 x 510
		底盤至爐面	76 x 580 x 510
		底盤至爐架	125 x 580 x 510
	開孔尺寸 - 闊 x 深 (毫米)	555 x 475	
	面板尺寸 - 闊 x 深 (毫米)	580 x 510	
	重量 (千克)	12.3	
電源供應	1.5 伏特 D 型鹼性電池 (1 枚)		
耗電量 (瓦)	/		
安全裝置	熄火安全裝置	熱電偶式	
	防高溫保護裝置	/	
	連續煮食自動熄火安全裝置	/	

Content

Important Safety Instructions	P.	1
Installation Instructions	P.	3
Operating Instructions	P.	5
Cleaning and Maintenance	P.	7
Troubleshooting	P.	8
Specifications	P.	9

Attention!

According to the Gas Safety Ordinance of Hong Kong, any gas installation works including the installation of appliances and connection tubing, must be undertaken by registered gas installers who are registered for that appropriate classes and be employed by registered gas contractors.

Important Safety Instructions

The following instructions are very important to safe operation of gas appliance. Please read through them carefully. Please contact 24-Hour Customer Service Hotline on 2880 6988 for enquiry and services.

Installation

1. Use approved gas tubing bearing EMSD approval marking (such as: 機電工程署批准 EMSD APPROVAL GTXXXX) for connection to appliance or other appropriate methods accepted by EMSD.
2. Check that the supply pressure is 1.5 kPa, external gas governor is not required for this appliance.
3. When installing gas appliance on top of kitchen cabinet, check that the air-intake opening at top plate (if applicable) is not blocked in order to ensure proper operation of the gas appliance.
4. Install the gas appliance in a well-ventilated room.
5. Do not store any flammable materials, sprays or pressurized containers near and inside the kitchen cabinet below appliance.
6. The appliance should be installed with a distance of more than 150mm away from surrounding combustible materials.

Operation

1. In case of suspected gas leak, open windows and shut off gas meter valve. Do not operate any electric appliances or switches. Do not use any phones on site. Contact Towngas Emergency Hotline on 2880 6999 with a phone outside the premises.
2. Please use the appliance properly according to the operating instructions.
3. This appliance is designed for domestic use only. Do not use it for commercial purposes.
4. Do not use appliance for any purposes other than cooking, e.g. drying clothes.
5. Open windows and turn on ventilation system before operating the appliance.
6. Do not allow kids to use appliance.
7. Do not leave operating appliance unattended.
8. Do not add aluminum discs to burners. This will incur combustion problem.
9. Use the original manufacturer approved accessories only to avoid possible risks to health or property, such as carbon monoxide poisoning or fire.
10. Ensure that burner cap and burner body are not deformed. Contact Customer Service to replace the parts if deformation is found.
11. Before use, ensure the burner cap, burner body and pan supports are in correct position and are not tilted.
12. Ensure that flame holes of burners are free from water and dirt.
13. Do not put weight exceeding 10kg on each pan support.
14. Pan support is heavy. Do not drop it.
15. Do not press the rotary knob for more than 10 seconds. If the burner is not ignited after 10 seconds, wait at least 1 minute before making further attempt.
16. Make sure that flame condition is uniform during operation.
17. Heed high temperature of top plate, burners and pan supports.
18. Do not use flat bottom cooking utensil with too large diameter to avoid the risk of scald by high temperature and reduce the service life of the appliance. When using small utensil, reduce flame power that flame does not escape from utensil bottom.

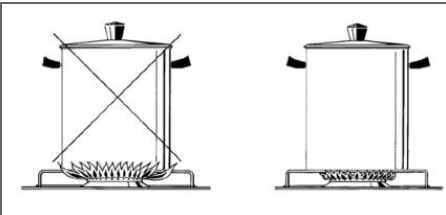
	Burner	Maximum Diameter of Flat Bottom Utensil (mm)
	Left Upper Burner	220
	Left Lower Burner	200
	Right Burner	280

19. Ensure stability of utensil resting on pan support. Hold utensil firmly if it slips easily.
20. Top plate is fixed. Do not remove it.

Important Safety Instructions

21. Do not fill water including soup ingredients over two-thirds of utensil volume when boiling water or soup. Spilled liquid of boiling will affect combustion and damage the appliance.
22. When the appliance is operating at low flame, do not open underneath cabinet door rapidly; otherwise, flame may be extinguished by air draught.
23. Always use cooking utensils with covers and make sure that the handles of the cooking utensils are correctly positioned to avoid heating and collision of handles.
24. Do not use sprays near the appliance.
25. All knobs should be turned to off position after use.
26. Clean the burner frequently to maintain a clear gas passage of flame holes. Clean and tidy up the burner after spillage of food and liquid once the appliance cools down.

Maintenance

1. Check condition of gas hose regularly. Ensure that it is free from kink or crack. Contact Customer Service to replace it if damage is found.
2. Allow the appliance to cool down completely before cleaning.
3. Wear glove to protect the hands from cut injury when cleaning the appliance. Do not touch any internal parts of the appliance.
4. Dry burner cap and burner body completely with dry cloth after washing. Flame holes of burner must be free from water lest combustion is affected.
5. Before and after use, notice the condition and cleanliness of burner. The following abnormal conditions will incur abnormal combustion and thus damage of the appliance. Ensure undertaking measures to rectify the problem accordingly.
6. Allow the appliance to cool down before performing any maintenance and cleaning. Please thoroughly clean water stains, soup and food residues on pan supports or burners. Dried residues may become tough stains and cause discoloration on the pan supports or burners.

Abnormal Condition	Handling Measure
Burner cap and burner body are deformed	Contact Customer Service to replace the parts.
Burner cap and burner body are tilted	Replace burner cap and burner body properly. Burner cap and burner body must not be tilted.
Burner flame holes are blocked by water	Dry burner cap and burner body with cloth and replace them properly.
Burner flame holes are blocked by dirt or cooking spillage	Clean burner cap and burner body with mild detergent and brush. Ensure that they are wiped dry before replacing them.

Installation Instructions

Installation Position

Install the appliance in a well-ventilated room, but do not install at the position of strong wind. Keep it away from any flammable objects (such as paper, plastic, oil), combustible, sprays or pressurized containers. The appliance should be installed with a distance of more than 150mm away from surrounding combustible materials. Allow 650mm or more clearance above appliance. Install a range-hood at a distance of not less than 650mm from the surface of pan support of appliance. If the range-hood requires a different installation distance, adopt the larger value. The combustion products of appliance shall be evacuated by means of range-hood.

The appliance can be installed in below dimension.

- **Cut-out dimension : W555 x D475 mm**
Reserve cut hole on bench-top according to Fig.1.
Depth of bench-top should be 600mm or more.

If another appliance (e.g. dishwasher, washer) is to be installed under the gas appliance, keep a clearance of at least 10mm from the bottom of the appliance. If the installation instructions of the appliance underneath require a different distance, adopt the larger value. If an airflow generating appliance or device (such as built-in oven, clothes dryer) is to be installed under the built-in gas appliance, a partition shelf must be added and sealed with silicone gel. This prevents air draught affecting the appliance operation.

Appliance Installation

Position the appliance onto the bench-top opening. Secure the base tray with screw. Sealing gasket should be affixed around the entire periphery of top plate bottom. Position the top plate properly onto the bench-top. Then put the rotary knobs in correct position.

Gas Connection

Connect the gas appliance to the gas supply according to the prescribed standards in force and ensure that the appliance matches with the type of gas supply. Furthermore, check that the supply pressure is 1.5 kPa, external gas governor is not required.

 Attention	<ul style="list-style-type: none">• The gas connection of the appliance is 1/2" BSP male thread. Use approved gas tubing for connecting to appliance. Flexible tubing must not be longer than 2000 mm. Make sure that the tubing does not touch any moving parts and is not kinked or compressed.• After installation, check gas soundness of piping. Never use naked flame for checking.
---	--

Installation of Battery

Before use, the battery must be installed correctly. Appliance does not operate if batteries are placed wrongly.

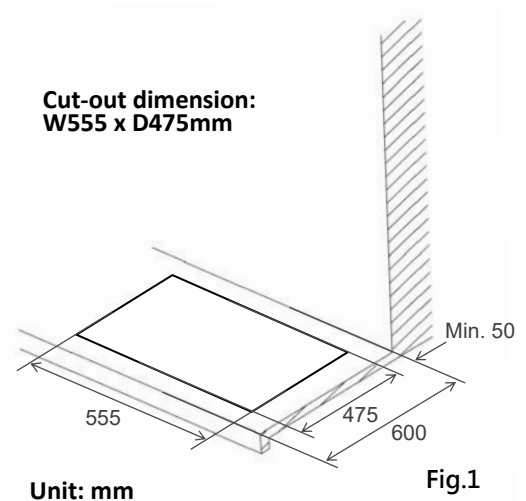

Installation Instructions



Attention

Fix stainless steel top plate securely to base tray of appliance!

- Position stainless steel top plate hole with burner, ignition electrode and flame failure safety sensor, then fix properly.
- Fix the stainless steel top plate with screws.

Placement of Burner

Make sure that the following parts are fitted properly before use.

- Right burner is composed of outer ring burner cap, simmer burner cap and burner body.
- Left burners are composed of burner cap and burner body.
- Place the burner caps and body onto the burner base without tilting.
- Locating pin of right burner body should be matched with the locating notch of right outer ring burner cap.
- Locating pin of left burner body should be matched with the locating notch of left burner base.

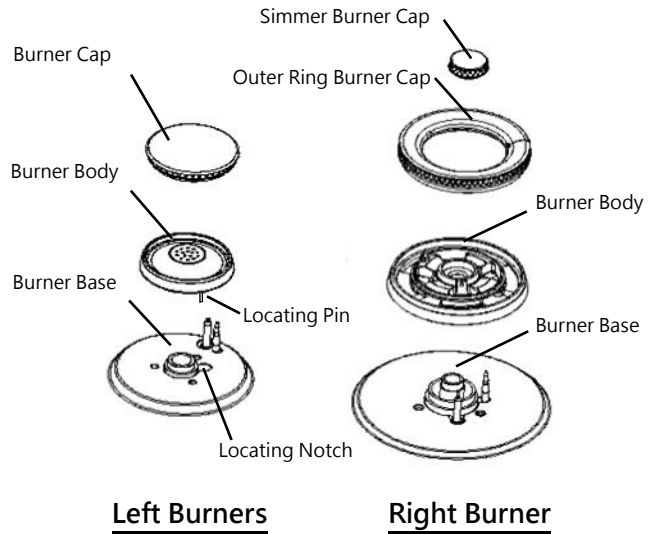

Do not use appliance with burner cap and burner body positioned improperly.

- It may not be ignited if burner cap and burner body are not fixed properly.
- It may cause incomplete combustion, risk of carbon monoxide poisoning and burner deformation, due to uneven flame shape and lighting back.
- It may cause flame getting into the appliance and damage it.

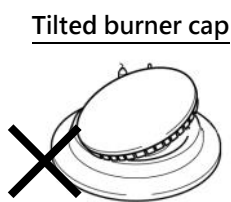
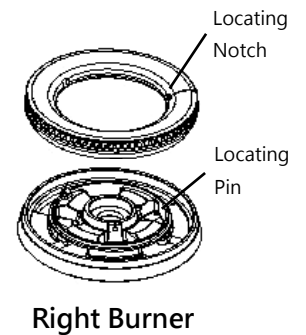

Left Burners

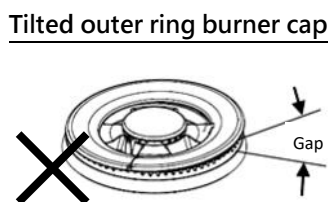

Right Burner

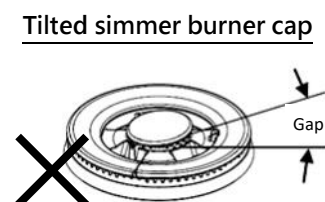

Placement of Pan Support

Make sure that the following parts are fitted properly before use.

- Place the pan support in position horizontally with the depression fit to the projection of panel.

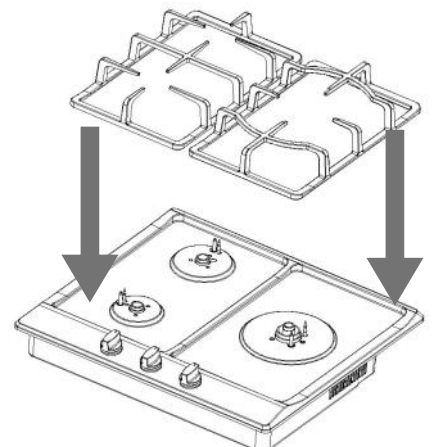

Do not use appliance with pan support positioned improperly. Due to improper fixing of pan support, cooking utensil may become unstable and cause hazard.

Operating Instructions

Appliance Descriptions

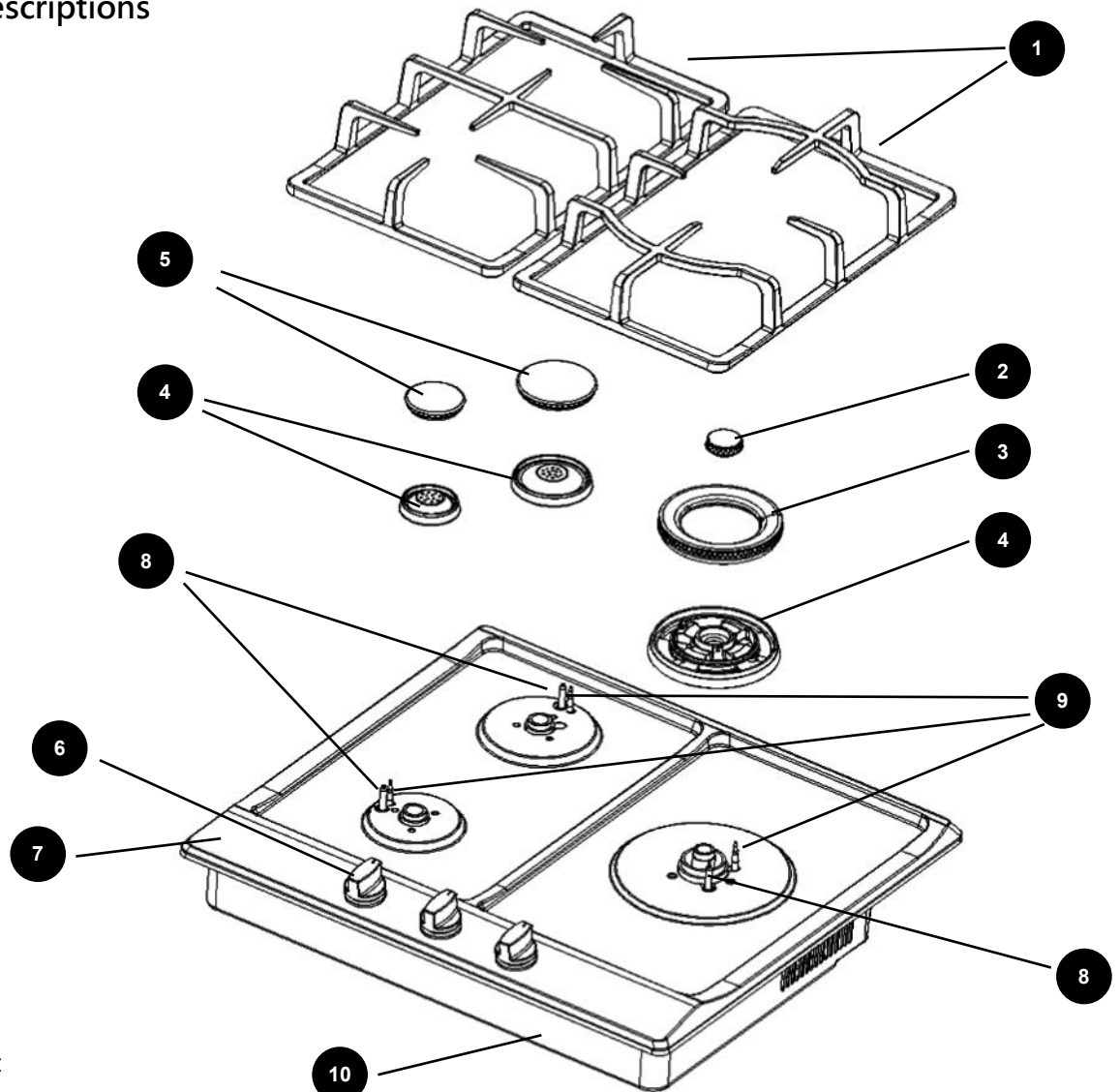

- 1 Pan support
- 2 Simmer burner cap
- 3 Outer ring burner cap
- 4 Burner body
- 5 Burner cap
- 6 Rotary knob
- 7 Stainless steel top plate
- 8 Ignition electrode
- 9 Flame failure safety device
- 10 Base tray
- 11 Battery box (located at left-front corner of bottom position)
- 12 Gas Connection

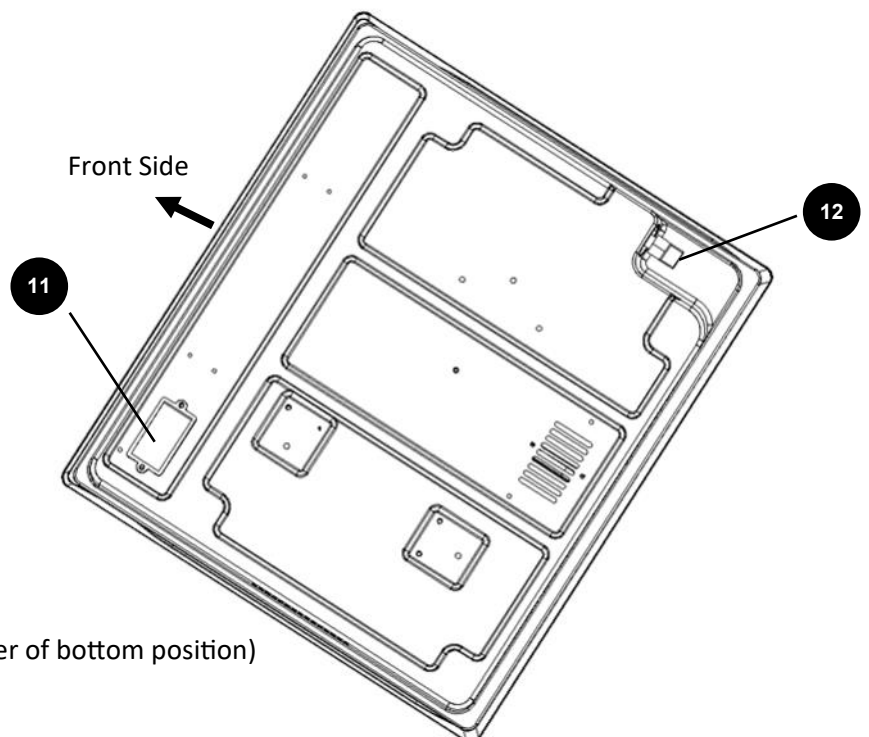

Operating Instructions

Rotary Knob and Indications

Ignition Position/ Maximum Flame Position	Medium Flame Position	Medium Flame Position	Minimum Flame Position	Off position



Attention

- When the appliance has been operated for 30 minutes, the stainless steel top plate and rotary knobs of the appliance might become hot due to the heat from flame. In case of needs for using the rotary knobs, please use a moisten towel to cool down before usage.

Ignition of Burner

Fully press and turn the rotary knob in anti-clockwise direction to ignition position. Electric sparks from ignition electrode ignite the burner. After releasing the rotary knob, make sure the flame persists.



Attention

- If the appliance has not been used for a long time, the first ignition may not succeed due to the trapped air in gas pipe.
- If the burner fails to ignite, turn the rotary knob to off position. Wait for at least 1 minute, repeat the above ignition procedures until success of burner ignition. Do not keep the pressing the rotary knob over 10 seconds.

Flame Control

After ignition, turn the rotary knob to adjust flame power according to cooking needs. Please adjust slowly. Minimum flame power is located at the end of anti-clockwise direction.



Attention

- When operating at low flame, do not open underneath cabinet door rapidly; otherwise flame may be extinguished by air draught.
- When adjust flame power from maximum close to medium, if flame of outer ring burner is found unstable (weak or extinguished), please adjust the flame power to maximum until flame of outer ring burner is stable, or reduce flame power and use flame of simmer burner. (if applicable)
- Pop sound might be generated during flame adjustment due to instant combustion of gas in burner. This is a normal phenomenon.

Turning Off Burner

Turn the rotary knob to the off position.



Attention

- Pop sound might be generated during flame extinguishing due to the instant combustion of gas remained in burner. This is a normal phenomenon.

Cleaning and Maintenance



Attention

- **Allow the appliance to cool down before performing any maintenance and cleaning.**
- **Wear gloves to protect the hands while cleaning.**

To maintain the appliance properly, follow the below instructions to clean it regularly:

General

- Do not use steam cleaners for cleaning.
- The metal and enamelled parts must be cleaned with suitable non-abrasive and non-corrosive detergents. Avoid using chlorine-based detergents (e.g. bleach).
- Avoid leaving acidic or alkaline substances on the appliance (vinegar, brine, lemon juice, etc).
- Clean and tidy up the burner after spillage of food and liquid once it cools down.
- Regularly check the flame failure safety device and ignition electrode. If stains get stuck at the devices, clean them with soft brush.
- Do not touch any internal parts of the appliance.
- Check the condition of gas tubing regularly. If damage is observed, contact Customer Service for replacement.

Cleaning Appliance

- Burner cap and body must be washed frequently with warm water and detergent, taking care to remove any grime and keep the flame holes of burner away from blockage.
- Dry the burner cap and body completely after wash and check all flame holes of burner are not clogged.
- Refix the burner cap and body at correct position. Ensure that they are not tilted or reversed.
- Any spilled food or liquid during cooking must always be removed by a dry rag.

Troubleshooting



Attention

Before restarting ignition, return the rotary knob to off position.

If abnormality or fault is observed, turn off flame. Ensure that the appliance cools down completely before undertaking remedial measures. If not effective after undertaking the following remedial actions, please contact 24-Hour Customer Service Hotline on 2880 6988 for services.

Fault	Cause	Remedy
1. No ignition spark	Batteries are consumed.	Replace batteries.
	Batteries are wrongly placed.	Place batteries correctly.
	Ignition electrode is dirty or wet.	Clean and dry ignition electrode.
2. No flame	Gas meter valve and/or appliance gas supply valve is turned off.	Open gas meter valve and/or appliance gas supply valve completely.
	Air is trapped inside gas pipe.	Repeat ignition until trapped air is removed.
	Burner is blocked by aluminium disc.	Remove aluminium disc.
	Ignition electrode is dirty or wet.	Clean and dry ignition electrode.
3. Flame does not persist	Flame failure safety device is dirty.	Clean flame failure safety device.
	Rotary knob is not fully pressed or not turned to ignition position.	Fully press and turn rotary knob to ignition position.
4. Flame off when using	Flame failure safety device is dirty.	Clean flame failure safety device.
	Small flame is blown off by wind. This activates the flame failure safety device.	Turn rotary knob to off position. Wait for 1 minute and restart ignition.
	When operating at low flame, open underneath cabinet door rapidly.	Turn rotary knob to off position. Wait for 1 minute and restart ignition.
5. Yellow flame	Burner cap and burner body have dirt.	Wash burner cap and burner body in warm water with detergent. Dry and replace them at correct position. Restart ignition.
6. Unstable flame	Deformation of burner cap and burner body.	Contact Customer Service to replace the parts.
	Incorrect placement of burner cap and burner body.	Turn rotary knob to off position. Replace burner cap and burner body correctly after appliance cools down and restart ignition.
7. Ignition sparks persist even after releasing rotary knob	Maintaining maximum 10 seconds of sparks to facilitate ignition.	Normal and no action required.
8. Abnormal noise when using	Incorrect placement of burner cap and burner body.	Turn rotary knob to off position. Replace burner cap and burner body correctly after appliance cools down and restart ignition.
9. Pop sound when flame adjusting or extinguishing	Instant combustion of gas remained in burner.	Normal and no action required.

Specifications

Model		HZB53M1		
Basic Specifications	Appliance Type		Gas Cooking Hob	
	Installation Type		Built-in Hob	
	Gas Type		Hong Kong Town Gas	
	Gas Supply Pressure (kPa)		1.5	
	Governor Outlet Pressure (kPa)		/	
	Gas Connection		1/2" BSP Male Thread	
	Ignition Device		Fast-easy Electronic Ignition	
	Number of Burner		3	
	Rated Heat Input (kW)	Left Upper Burner		2.5
		Left Lower Burner		1.3
		Right Burner		5
		Total		8.8
	Top Plate Material		Stainless Steel	
	Top Plate Thickness (mm)		/	
	Appliance Dimensions - H x W x D (mm)	Base Tray to Bench Top		55 x 580 x 510
		Base Tray to Top Plate		76 x 580 x 510
		Base Tray to Pan Support		125 x 580 x 510
	Cut-out Dimensions - W x D (mm)		555 x 475	
	Top Plate Dimensions - W x D (mm)		580 x 510	
	Weight (kg)		12.3	
Power Supply		1.5V D-size Alkaline Battery (1pcs)		
Power Consumption (W)		/		
Safety Devices	Flame Failure Safety Device		Thermocouple Type	
	Overheat Protection Device		/	
	Continuous Cooking Automatic Flame Off Safety Device		/	

